

E 7080

PD27

DRIVEN PILES KIT

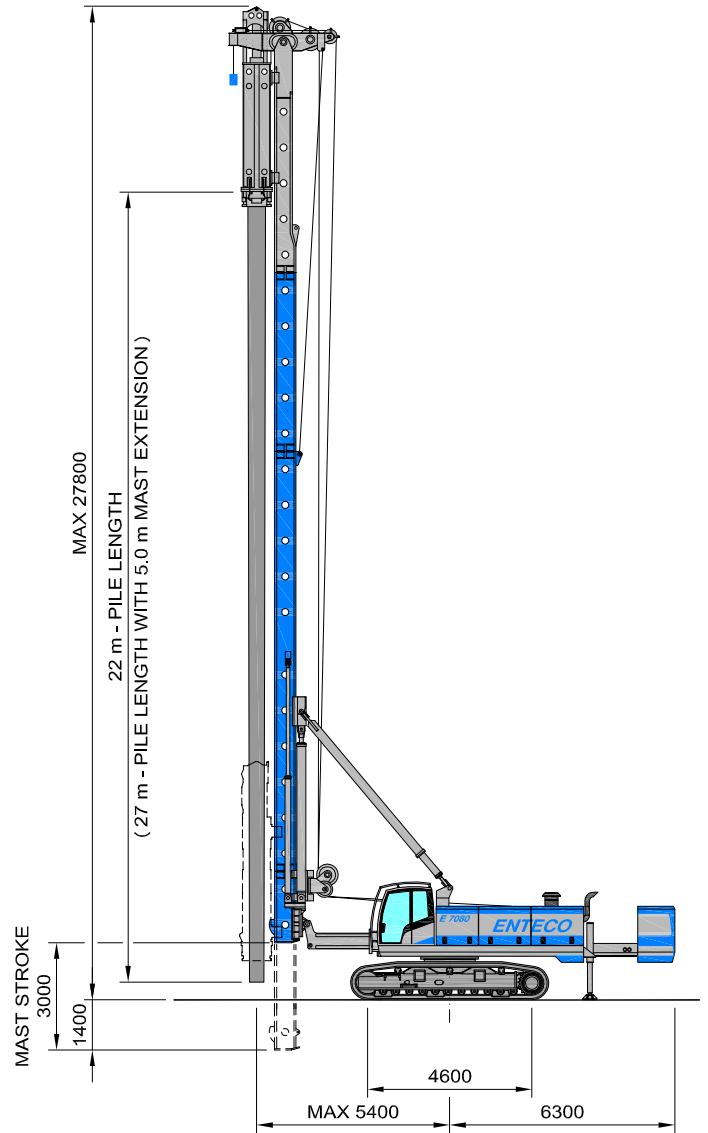
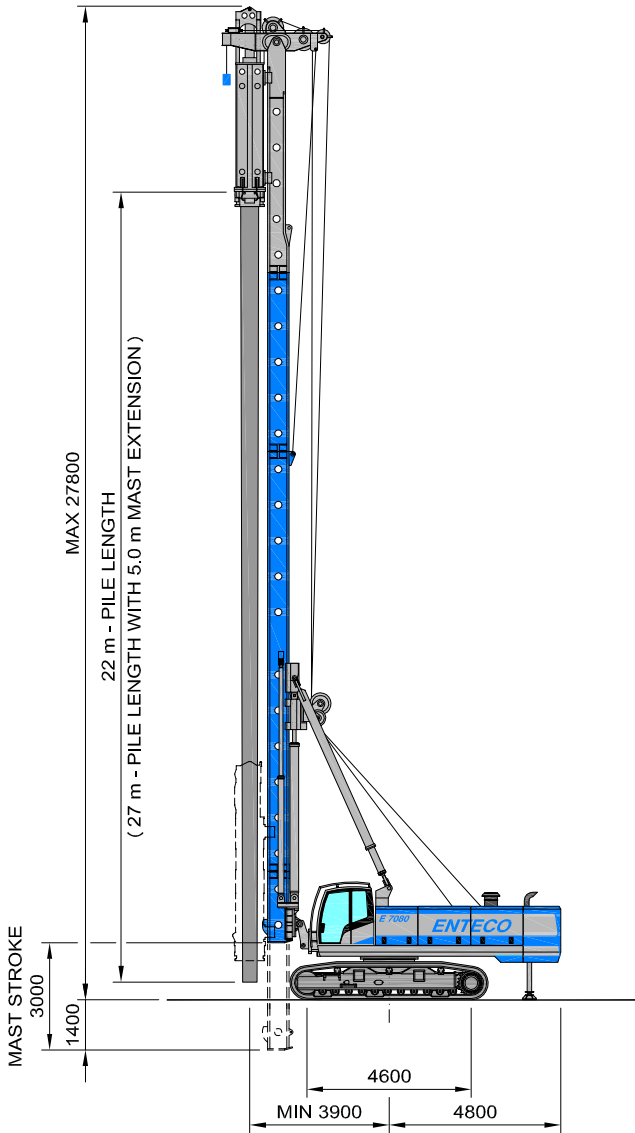

TRANSPORT DIMENSIONS WITH HAMMER

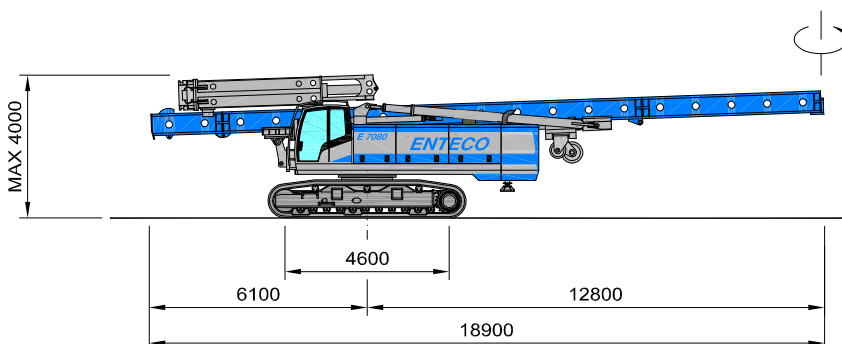

E 7080

PD27

DRIVEN PILES KIT

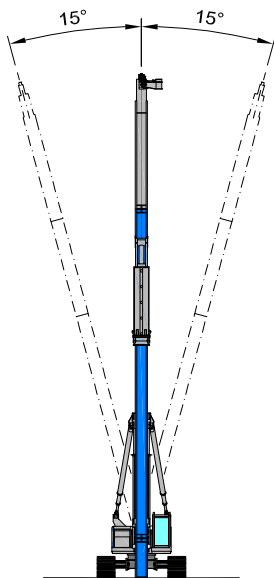
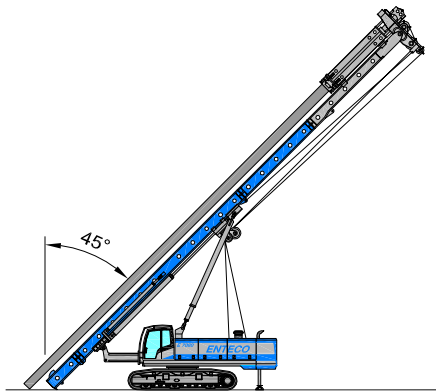
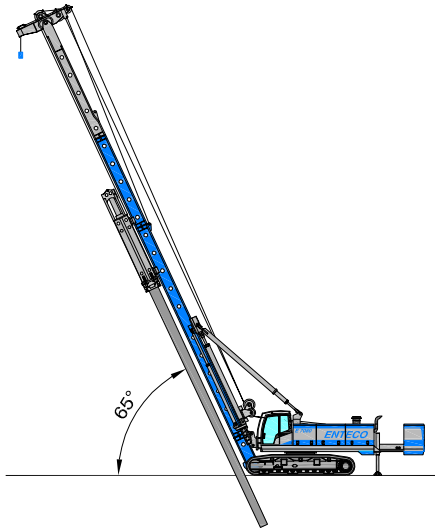

E 7080 - PD27 DRIVEN PILES KIT

MACHINE WEIGHT

Operating weight without hammer	kg	80000
Operating weight with hammer	kg	98000

HAMMER AND PILE

Max hammer weight	kg	18000
Max pile length without mast extension	m	22
Max pile length with 5 m mast extension	m	27

MAST

Standard mast length	mm	25400
Mast extension	mm	5000
Mast vertical travel	mm	3000
Mast forward stroke	mm	1500

COUNTERWEIGHT

Total weight	kg	12000
Counterweight stroke	mm	1500

E 7080 - BASE MACHINE

CRAWLERS

Overall width	mm	3000÷4500
Track pads	mm	900
Tramming speed	km/h	1.8

DIESEL ENGINE

Model	CATERPILLAR	C9 ACERT	C13 ACERT
Rated power	HP/kW	350/261	440/328
Fuel tank capacity	litres	750	

MAIN WINCH

Max line-pull 1st layer	kN	270
Free-fall device		installed

AUXILIARY WINCH

Max line-pull 1st layer	kN	150
Free-fall device		installed

TRANSPORT DIMENSIONS WITHOUT HAMMER

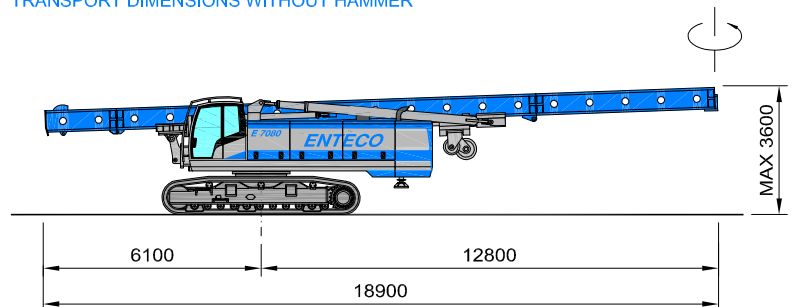

Via dell'Artigianato, 33 - Z.I. - 30020 Fossalta di Piave - VENEZIA - ITALIA
 Tel +39 0421 67.99.77 - Fax +39 0421 67.99.93 - e-mail: info@entecodrill.com - www.entecodrill.com

E7080 - PD27 108Q-039 20120228