

E 6080

R280

BORED PILES KIT

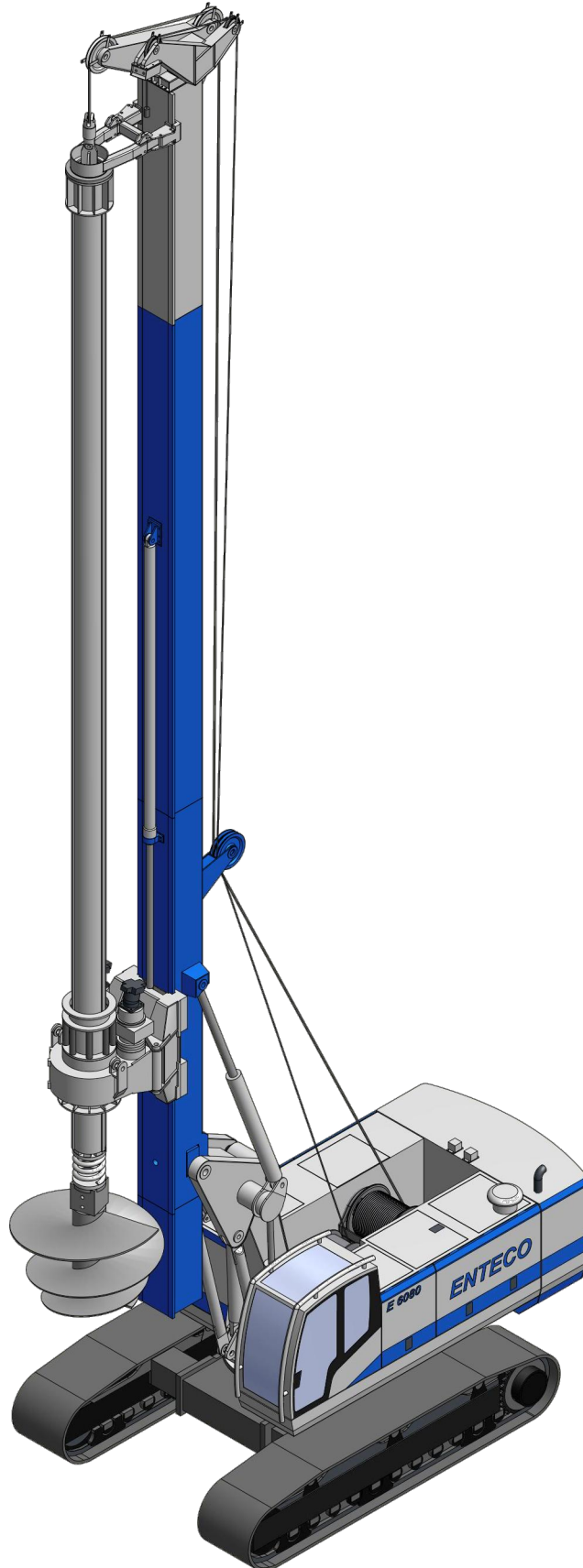

E 6080

R280

BORED PILES KIT

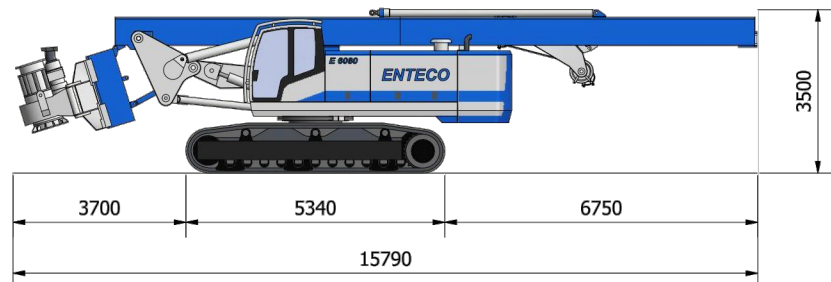
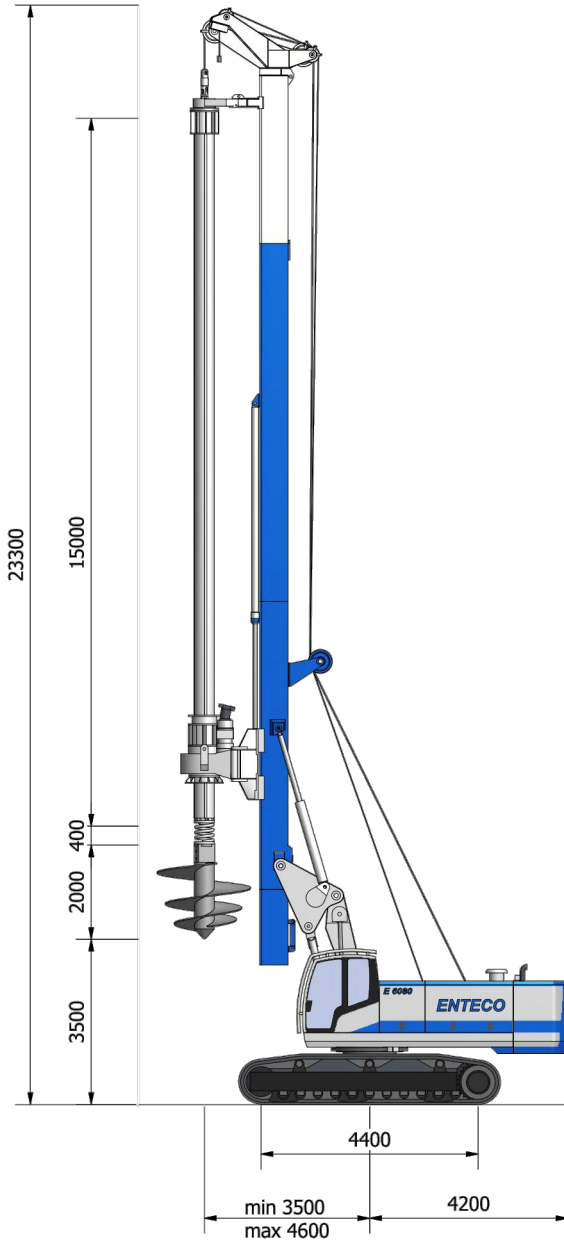

E 6080 - R280 BORED PILES KIT

OPERATING WEIGHT	ton	up to 82
Drilling diameter Auger in front of the mast	mm	2000
Drilling diameter Auger beneath the mast	mm	2500
Max drilling depth	m	70

MAST

Front/Rear inclination	+4°/-15°
Side inclination	±4°

CROWD SYSTEM

CYLINDER

Rotary stroke	mm	5100
Crowd force	kN	300
Extraction force	kN	240

ROTARY

Model	ENTECO RH51/2	
Max torque	kNm	280
Max drilling speed	rpm	28
Spin-off speed	rpm	160

INTERLOCKING KELLY-BAR

Type - elements/length	4x12 m 4x15 m	
Max depth	m	44 56
Weight	kg	7400 9000

FRICITION KELLY-BAR

Type - elements/length	5x12 m 5x15 m	
Max depth	m	55 70
Weight	kg	8500 10500

E 6080 - BASE MACHINE

CRAWLERS

Overall width	mm	3000+4500
Track pads	mm	900
Tramming speed	km/h	1.5

DIESEL ENGINE

Model	CATERPILLAR	C9 ACERT	C13 ACERT
Rated power	HP/kW	350/261	440/328
Fuel tank capacity	litres	500	

MAIN WINCH

Max line-pull 1st layer	kN	240
Free-fall device		option

AUXILIARY WINCH

STANDARD OPTION

Max line-pull 1st layer	kN	70	100
Free-fall device		option	option



Via dell'Artigianato, 33 - Z.I. - 30020 Fossalta di Piave - VENEZIA - ITALIA
Tel +39 0421 67.99.77 - Fax +39 0421 67.99.93 - e-mail: info@entecodrill.com - www.entecodrill.com

E6080 - R280 111Q-203 20120704